

# WOLSELEY MERRY TILLER

## Instructions for Operation and use as a Cultivator

### MODELS:

**Merry Tiller Major**, 4 h.p. Briggs and Stratton engine,  
Fixed or Adjustable Handles.

**Merry Tiller Super Major**, 5 h.p. Briggs and Stratton engine,  
Adjustable Handles.

Late 1976 onwards.

### IMPORTANT

Please read Sections 1 and 2 of this booklet and the engine booklet before using your machine.

Also refer to Section 3 on Maintenance for after use and storage.

**Note:-** Whilst the illustrations in this booklet apply to each machine as above, they are of the Merry Tiller Major.

MANUFACTURED BY

**WOLSELEY WEBB LIMITED**

ELECTRIC AVENUE WITTON . BIRMINGHAM B6 7JA

Telephone 021 328 1314 Telex. 339388 Telegrams & Cables Wolwebb Birmingham Telex

COVER

Copied from the original Merry Tiller Manual circa 1976

Produced by allotment.org.uk in response to requests

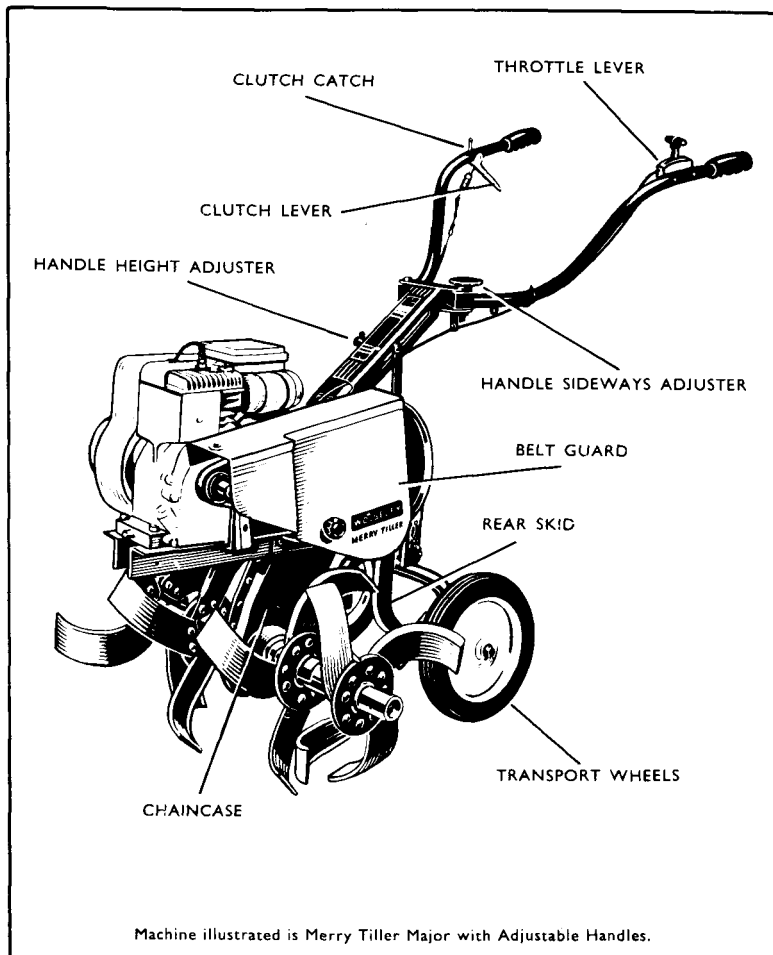

## CONTENTS

		PAGE
<b>Section 1.</b>	Before Use	<b>3</b>
<b>Section 2.</b>	Use	<b>3</b>
<b>Section 3.</b>	Regular Maintenance	<b>5</b>
<b>Section 4.</b>	General Information	<b>8</b>
<b>Section 5.</b>	Spare Parts	<b>8</b>

The terms RIGHT or LEFT hand used in this booklet refer to the machine and parts as viewed by the operator at the rear of the machine facing forward. All rotors and wheels are marked with Green paint for right hand and Red paint for left hand.

## SECTION 1 BEFORE USE

### Preparing the ENGINE UNIT

The engine operating booklet supplied with your Merry Tiller gives full details of pre run and starting procedure. Please refer to this booklet. Remember that on a new Merry Tiller there is no oil in the engine sump nor in the chaincase.

The engine unit is a four stroke petrol engine and NO OIL should be put in the petrol tank.

### Preparing the MERRY TILLER

The transmission chaincase should receive 1 pint of S.A.E. 30 oil or oil as specified for the engine.

To Fill: Pull out the oil filler plug. Lean the machine onto its left side and pour in the oil. Replace the plug.

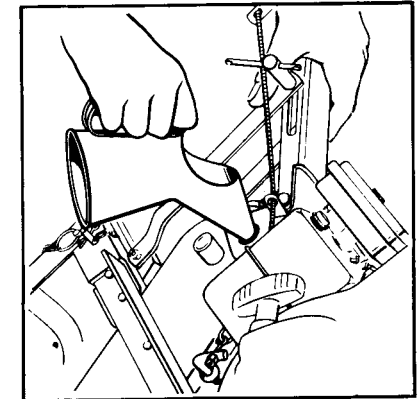

As the chaincase has no high speed moving parts there is no possibility of oil escaping in the form of spray, and unless the oil leaks from the case then the level of oil in the case will remain constant. It is, however, advisable to change the oil in the chaincase periodically but not as regularly as the oil in the engine.

## SECTION 2 USE

**To Start the Engine:** Refer to the Engine Booklet.

### IMPORTANT

Ensure clutch is in released position before attempting to start the engine.

- (1) Pull out choke 'A' on carburettor. (See illustration overleaf).
- (2) Push throttle lever into fast running position marked 'F'.
- (3) Pull the starter cord evenly and without jerking.  
Allow the cord to return steadily avoiding 'springing back' which can damage the starter mechanism.

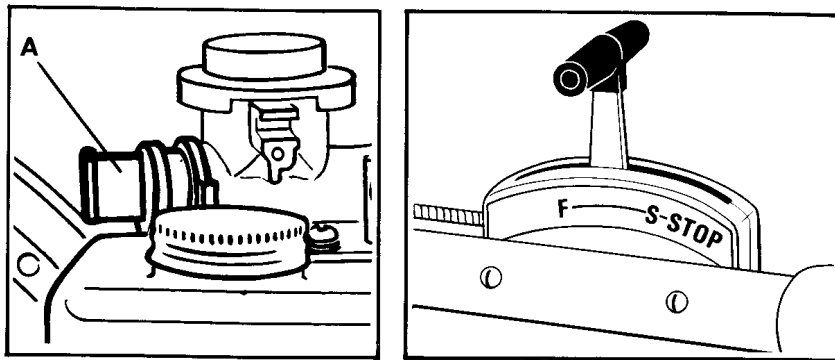

### Running

Once the engine starts, push choke W in by hand. Engine speed can be reduced by pulling the throttle lever back towards 'S' and increased by pushing the lever towards 'F'.

### To Stop Engine

Move throttle lever into the 'Stop' position.

### To Operate the MERRY TILLER

Select the rotors for your particular job and attach them to the rotor shaft with the pins and spring clips provided, noting that the head of the pin should lean forward at the top at all times to ensure that the clip remains closed.

When at the area to be cultivated, remove the transport wheels or turn them upside down on the hitch casting.

### In Work

Ideally, when the machine is at its required working depth, then the operators position in relation to the machine should be such that the arms are almost straight and the body virtually upright.

Whilst there is no setting position in relation to the rear skid to give a set depth it should be set so that the length of the skid below the centre line of the machine is approximately the depth required. On machines with Adjustable Handles further adjustment can be made on the handles for comfort in operation.

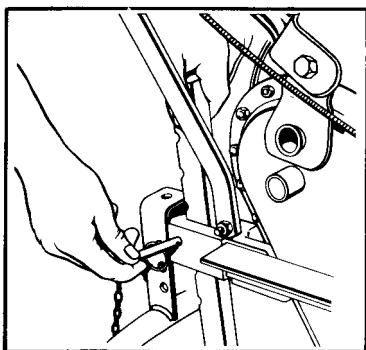

Start the engine and set it at half throttle. Push the rear skid into the ground and slowly raise the clutch lever when the rotors will turn. Press down on the handles until the machine has dug to the depth required and then apply only sufficient pressure to the handles to maintain that depth. To dig more deeply apply more pressure to the handles and release pressure to dig less deeply.

### Adjusting rear skid height.

4

## FURTHER OPERATING SUGGESTIONS

To control the depth of tilling, the Merry Tiller must be operated with both the proper throttle speed and correct up and down pressure on the handles. Raising up means going forward, as by so doing the skid bar is allowed to come out of the ground and the machine moves forward. Pushing down means slowing the machine as the skid is pushed further into the soil, at the same time the machine will dig deeper. When you are first learning to use your Merry Tiller it is not unlikely that it will tend to buck or move from side to side. This tendency will soon be overcome with use.

To acquire the knack of letting the machine do the work without effort on the part of the operator, we offer the following suggestions.

- 1 Concentrate on keeping your arms relaxed.
- 2 When working across a slope turn the front of the machine slightly uphill to combat any tendency for the machine to run downhill.
- 3 For best results operate at reduced throttle settings when the ground is very hard or rough.
- 4 Do not hurry the job proceed at a slow walk thus giving the machine time to do its work.
- 5 It is advisable to re adjust the height of the rear skid to maintain the correct height of the handles, after the tiller has dug down to its required depth.
- 6 The rear wheels may be used to steady the machine in work but should never be used as a depth control.
- 7 It is better to release the clutch and go over the ground again if the machine starts to run away, rather than straining to hold it back which should not be necessary.
- 8 Cultivate only when it is suitable to do so. Frozen or waterlogged ground, if cultivated, can cause poor soil moisture movement.
- 9 Cultivate at a different depth each season to stop the possibility of 'panning' in the sub soil.

## SECTION 3 REGULAR MAINTENANCE

### ENGINE

Refer to the engine booklet. In very dusty conditions it may be necessary to change the oil in the engine and certainly in the air cleaner more often than recommended.

Remember that the engine unit depends upon the flow of air over the cylinder head and barrel for efficient cooling.

Do not allow dirt or trash to build up in the cooling fins or behind the metal cowlings.

### Throttle Control Adjustment

#### IMPORTANT

Do not attempt to adjust throttle control with the engine running.

5

With the throttle lever pushed fully forward i.e. past 'Fast' running position, bend the inner core of the throttle cable at right angles 1 5/8" from the outer cable end. Next bend cable at right angles again as shown below

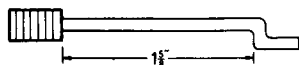

Feed cable between petrol tank bracket and the rear of the blower housing. Fit clamp in place over the outer cable and lightly tighten clamp screw. Insert inner cable through the nut on the end of the vertical throttle link rod.

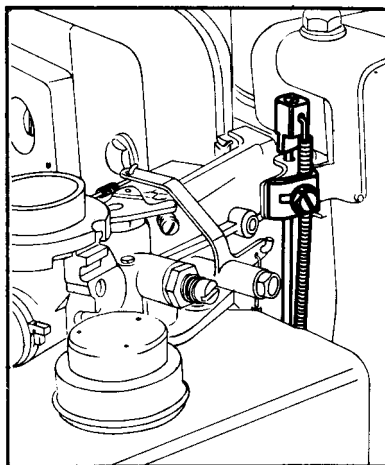

Adjust the outer cable in the clamp until approximately 1 1/4" protrudes above the top of the clamp. Pull the throttle control lever into the 'STOP' position and, if setting is correct, the cut out mechanism on the carburettor will operate. If the cut out does not operate, draw the outer cable down through the clamp until the cut out operates. If the cut out operates before the throttle lever is in the 'STOP' position push outer cable up through the clamp to adjust. When the correct setting and operation is obtained tighten clamp screw.

Refit the air filter.

## TRANSMISSION CHAINCASE

On the chaincase there is no oil level indicator as for reasons previously stated, providing there is no oil leak, then the level will remain constant.

It is suggested that the oil in the case be changed each season as even though there are no fast moving parts, the oil will tend to lose its lubricating properties after a time.

## CLUTCH ADJUSTMENT

The clutch should engage when the lever is raised about two thirds. When disengaged the belt should be completely slack and not binding in the engine pulley. Always use the correct belt. The Merry Tiller is supplied with a specially made belt which has a low length tolerance variation and non rubberised casing. This gives the correct clutch control for this machine and a rubber cased belt may cause creeping forward of the machine due to friction.

**IMPORTANT** Do not attempt to adjust the clutch with the engine running.

### Initial Adjustment

The clutch cable provided has a standard length with adjusting links at the lever end. Connect the control spring to link 5 before adjusting dutch. This will give the correct overall length of cable. Remove the belt guard by releasing the holding knob.

Undo adjustment nut A so that the clutch wire is slack and the nut at its lowest position.

Loosen nut B. This locks the idler arm in relation to the spindle. Adjust the idler arm in relation to the spindle to take up some of the slack on the belt. Retighten nut B.

Sufficiently tighten nut A to correctly set the clutch.

If it is found that the idler pulley wheel is not in line with the engine and drive pulleys, adjustment can be made by turning the idler arm in relation to the spindle, in or out.

To do this it will be necessary to remove the lower guard bracket.

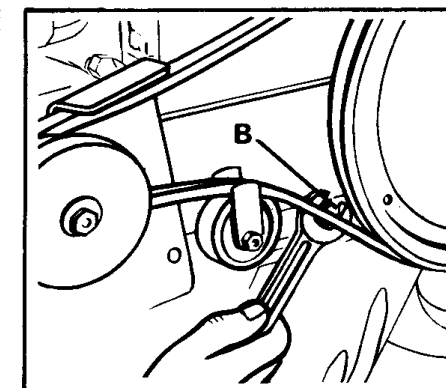
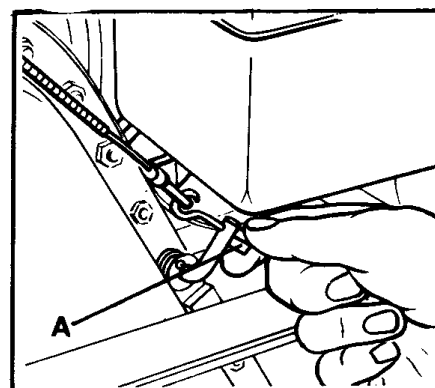

### Further Adjustment

If it is noted that the clutch is getting slack due to possible stretching of the cable and/or belt then this slack can be quickly taken up by turning nut A on the hook bolt.

### BELT SLIPPAGE

Always use the correct Merry Tiller belt. This can only be obtained from your dealer. Do not use rubber cased belts.

### OIL SEALS

If oil leaks from the seals on the rotor shaft then this is a job for your dealer as these cannot be removed without special tools.

Oil leaking at the drive shaft (top) seal can be easily overcome. First remove the drive pulley, key and washer, and then prise out the old seal with a screwdriver.

Make sure that the keyway and shaft are free from any dirt or burrs before fitting the new seal.

Place the seal in position and tap evenly all round until seated. Replace the washer, key and pulley and make sure that the grub screw in the pulley is tight.

### GENERAL HINTS

- 1 When storing the Merry Tiller for long periods, make sure that the engine is stored as per the instructions.
- 2 Make sure that all nuts and bolts are tight before and after use.
- 3 Do not carry out adjustments to the engine or clutch of the machine with the engine running.
- 4 It is advisable to have your machine overhauled periodically by your dealer.
- 5 The life of your machine will be greatly improved if it is kept clean.

### SECTION 4 GENERAL INFORMATION

Merry Tiller Major with Briggs and Stratton Engine. Engine power is 4 h.p. at 3,600 r.p.m. (American rating) Engine Capacity is 171 c.c. Tank Capacity is 5 pints petrol.

Merry Tiller Super Major with Briggs and Stratton Engine. Engine Power is 5 h.p. at 3,600 r.p.m. (American rating). Engine Capacity is 206 c.c. Tank Capacity is 5 pints petrol.

Rotor speed on each machine is 118 r.p.m. at 3,600 r.p.m. at the engine.

Rotor speed on each machine is 80 r.p.m. at 2,500 r.p.m. at the engine.

All machines are fitted with recoil starters, two stage reduction chaincases with oil bath lubrication. Final drive is by heavy duty rotor shaft.

Constructed in heavy gauge angle steel mounts, cast steel hitch Assembly and heavy gauge steel tube handles.

### SECTION 5 SPARE PARTS

When ordering spare parts make sure that you quote the Model, Part Number and Description. This will help your dealer to supply the correct part quickly.

If the part that you require is not listed in this booklet due to changes which have occurred in design, then your dealer has a complete master spare parts list and can advise you accordingly.

Engine parts are not available from this factory and should be obtained from Messrs Autocar Electrical Co. Ltd., Rippleside Trading Estate, Ripple Road, Bark-ing, Essex., or their respective dealer in your area or from Briggs and Stratton.

### TRANSPORT WHEEL ASSEMBLY

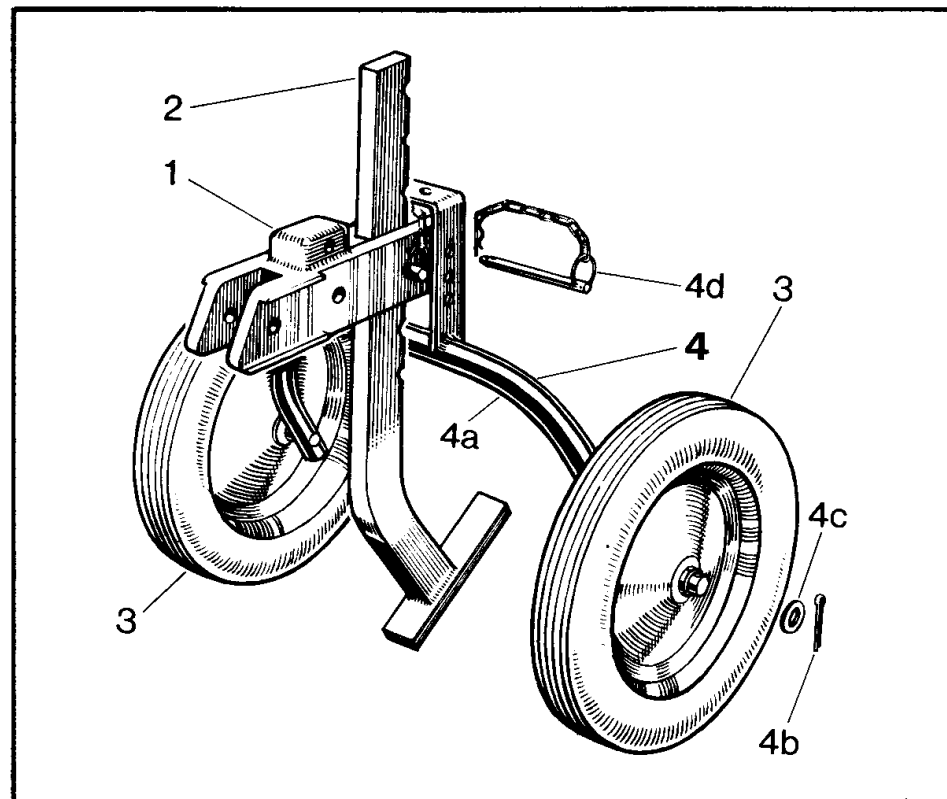

Item No.	Part No.	Part Name	Quantity per Machine
1	MT.2287	Hitch Casting	1
2	MT.2295	Rear Skid	1
3	MT.4576	Wheel	2
4	MT.3605	Wheel Frame Assembly	1
<i>Comprises:</i>			
4a	MT.2290	Wheel Arch	1
4b	MT. 1561	Split Pin	2
4c	W/8/S.ZP	Washer	4
4d	MT.2506	Hitch Pin Assembly	2

# ENGINE MOUNT ASSEMBLY

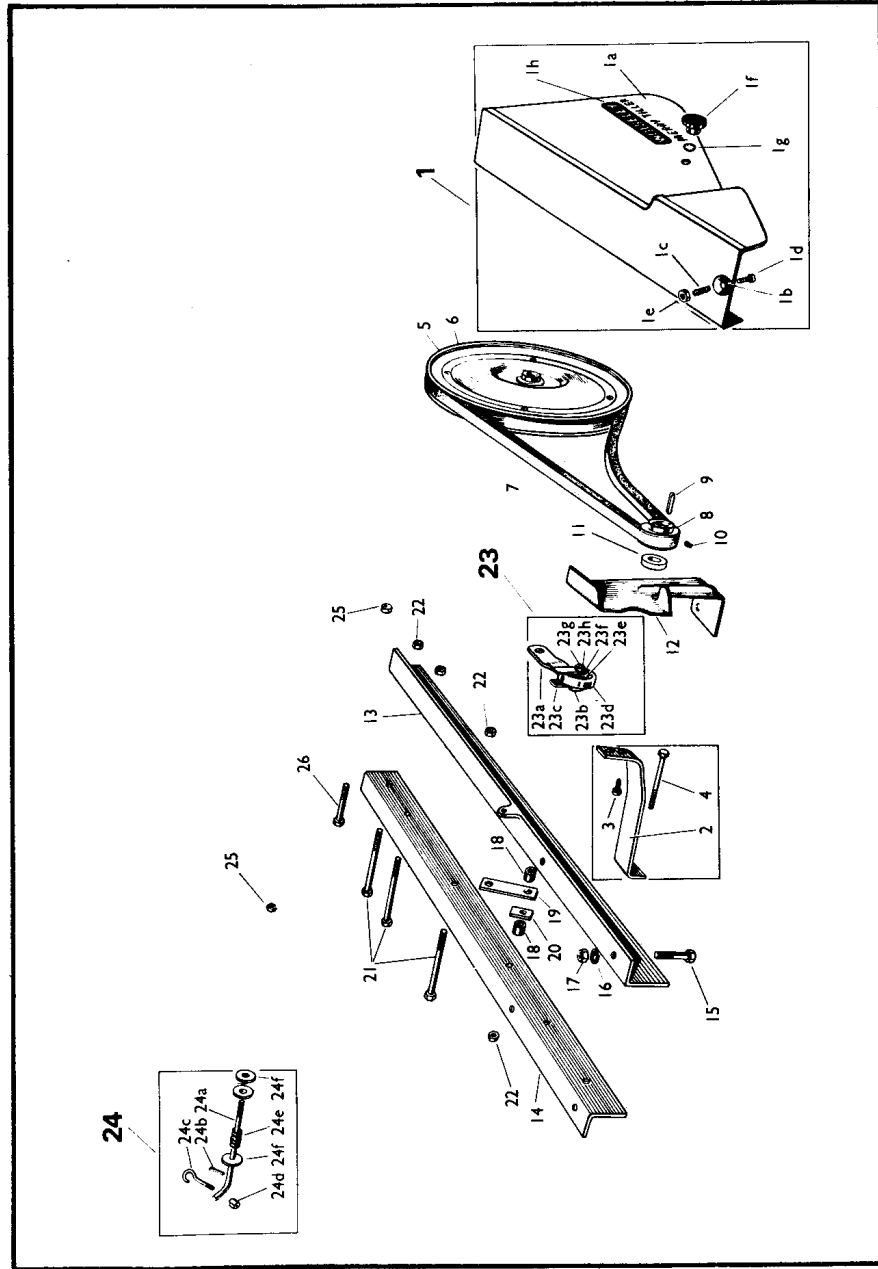

10

ITEM No.	PART No.	PART NAME	Quantity per Machine
1	<b>MT. 4256</b>	Guard Assembly	1
	(Comprising)		
1a	<b>MT.3540</b>	Guard	1
1b	<b>MT.3164</b>	Dished Washer	1
1c	<b>MT.3170</b>	Spring	1
1d	<b>2BAS/700/8/S.ZP</b>	Screw	1
1e	<b>2BAN/100/S.ZP</b>	Nut	1
1f	<b>MT.3168</b>	Plastic Knob	1
1g	<b>FD.5</b>	Washer	1
1h	<b>MT. 4176</b>	Transfer	1
2	<b>MT.3620</b>	Lower Guard Support Bracket	1
3	<b>WS/105/10/R.ZP</b>	Screw	1
4	<b>UFB/105/42/SS.ZP</b>	Guard Bracket Bolt	1
5	<b>MT.2447</b>	Transmission Pulley	1
6	<b>MT.3307</b>	Grub Screw (Not shown)	1
7	<b>MT.3371</b>	Drive Belt	1
8	<b>MT.777</b>	Engine Pulley	1
9	<b>MT. 2925</b>	Key	1
10	<b>MT.2042</b>	Grub Screw	1
11	<b>MT.4144</b>	Engine Shaft Spacer	1
12	<b>MT.701</b>	Belt Guide	1
13	<b>MT.4136</b>	L.H. Motor Mount	1
14	<b>MT.4135</b>	R.H. Motor Mount	1
15	<b>UFB/105/24/SS.ZP</b>	Bolt, B. & S. Engine	4
16	<b>LW.5</b>	Washer	4
17	<b>UFN/105/S.ZP</b>	Nut	4
18	<b>MT.2869</b>	Spacer	2
19	<b>MT.2962</b>	Chaincase Support L.H.	1
20	<b>MT.2961</b>	Chaincase Support R.H.	1
21	<b>UFB/105/44/SS.ZP</b>	Bolt	3
22	<b>MT.2857</b>	Locknut	4
23	<b>MT.4137</b>	Idler Arm Assembly	1
	(Comprising)		
23a	<b>MT.4143</b>	Idler Arm	1
23b	<b>UFS/504/28/S.ZP</b>	Csk. Hd Screw	1
23c	<b>MT.129</b>	Side Plate	2
23d	<b>MT.333</b>	Skate Wheel	1
23e	<b>MT.4036</b>	Felt Washer	2
23f	<b>MT.3611</b>	Domed Washer	2
23g	<b>LW/4</b>	Washer	1
23h	<b>UFN/104/S.ZP</b>	Nut	1
24	<b>MT.3744</b>	Clutch Adjusting Assembly	1
	(Comprising)		
24a	<b>MT.3643</b>	Idler Arm Spindle	1
24b	<b>B.764</b>	Cotter Pin	1
24c	<b>MT.3637</b>	Hook Bolt	1
24d	<b>MT.3645</b>	Grooved Nut	1
24e	<b>MT.1237</b>	Spring	1
24f	<b>W6/S/SL/ZP</b>	Washer	2
25	<b>MT.2931</b>	Locknut	2
26	<b>UFB/106/32/SS.ZP</b>	Bolt	1

11

## TRANSMISSION CASE ASSEMBLY

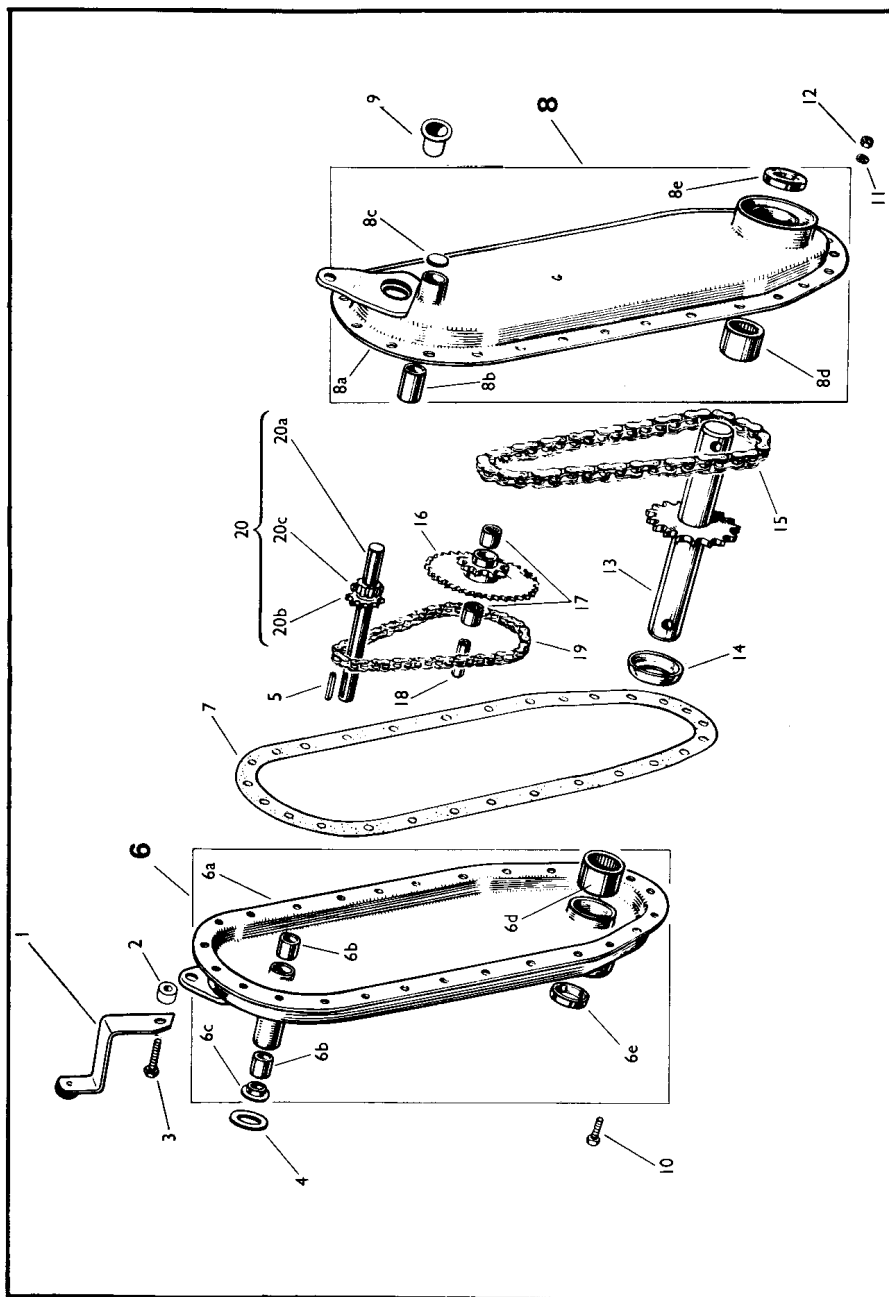

12

## CHAINCASE ASSEMBLY

ITEM No.	PART No.	PART NAME	Quantity per Machine
1	<b>MT.3541</b>	Top Support Bracket	1
2	<b>MT.4145</b>	Top Support Bracket Spacer	1
3	<b>UFS/104/16/SS.ZP</b>	Bolt	1
4	<b>W10/S/SL/ZP</b>	Washer	1
5	<b>MT.375</b>	Key	1
6	<b>MT.4138</b>	L.H. Chaincase Half Assembly	1
	(Comprising)		
6a	<b>MT.4140</b>	L.H. Case Half	1
6b	<b>MT.345/1</b>	Drive Shaft Bearing, Short	2
6c	<b>MT.342</b>	Oil Seal	1
6d	<b>MT.343</b>	Rotor Shaft Bearing	1
6e	<b>MT.344</b>	Rotor Shaft Oil Seal	1
7	<b>MT.105</b>	Gasket	1
8	<b>MT.4078</b>	R.H. Chaincase Half Assembly	1
	(Comprising)		
8a	<b>MT.4080</b>	R.H. Case Half	1
8b	<b>MT.345</b>	Drive Shaft Bearing, Long	1
8c	<b>MT.295</b>	Upper Boss Plug	1
8d	<b>MT.343</b>	Rotor Shaft Bearing	1
8e	<b>MT.344</b>	Rotor Shaft Oil Seal	1
9	<b>MT.3735</b>	Filler Plug	1
10	<b>UFS/104/8/SS.ZP</b>	Hexagon Screw	24
11	<b>LW.4</b>	Washer	25
12	<b>UFN/104/SS.ZP</b>	Nut	25
13	<b>MT.147/1</b>	Rotor Shaft	1
14	<b>MT.651</b>	Spacer	1
15	<b>MT.347</b>	Chain $\frac{5}{8}$ " Pitch	1
16	<b>MT.1085</b>	Idler Sprocket	1
17	<b>MT.351</b>	Idler Sprocket Bearing	2
18	<b>MT.352</b>	Inner Race	1
19	<b>MT.348</b>	Chain $\frac{3}{8}$ " Pitch	1
20	<b>MT.4139</b>	Drive Shaft Assembly	1
	(Comprising)		
20a	<b>MT.4142</b>	Drive Shaft	1
20b	<b>MT.927</b>	Sprocket	1
20c	<b>MT.3779</b>	Spirol Pin	1

13

# ADJUSTABLE HANDLEBAR ASSEMBLY

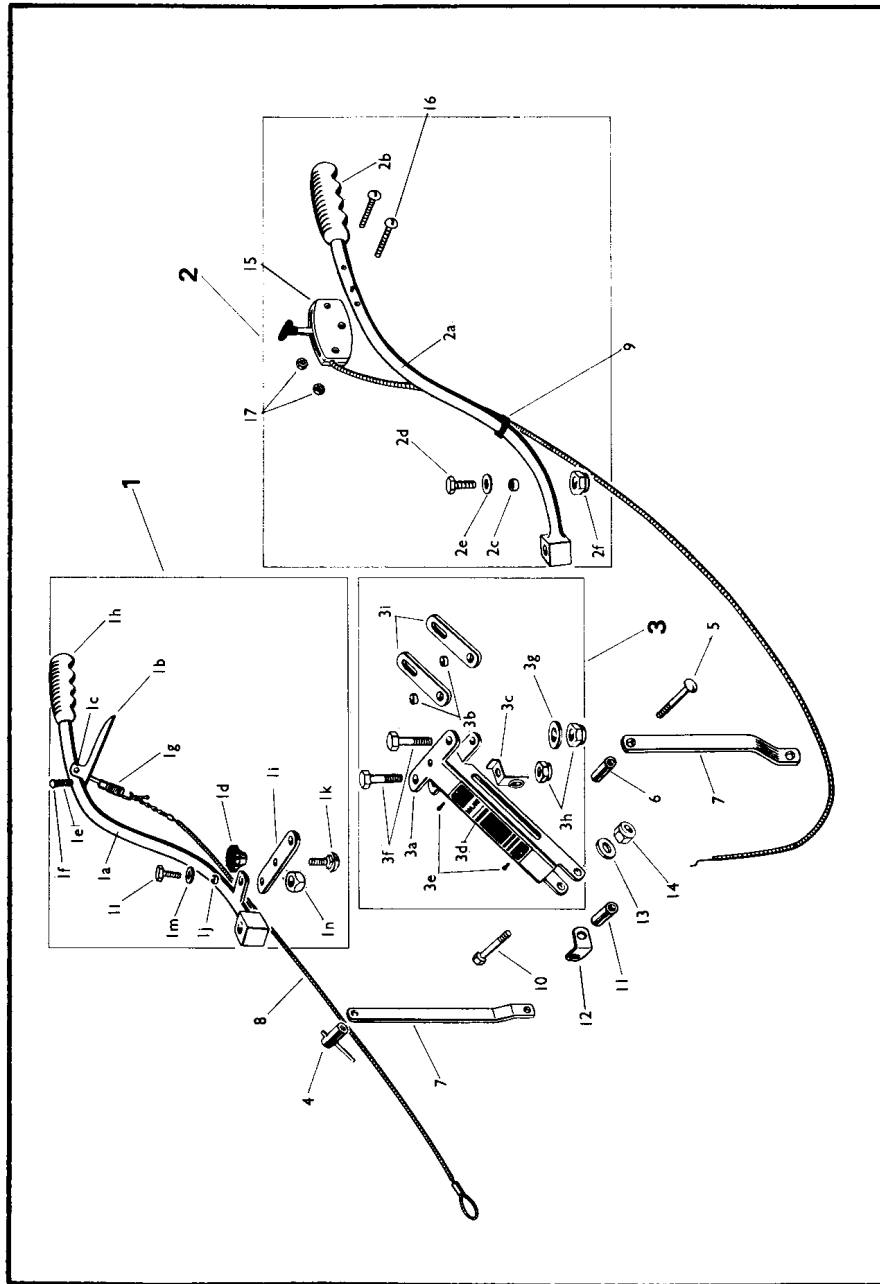

14

ITEM No.	PART No.	PART NAME	Quantity per Machine
1	<b>MT.3527</b>	Handlebar Assembly R.H.	1
	(Comprising)		
1a	<b>MT.3531</b>	Handlebar Weld Assembly R.H.	1
1b	<b>MT.3311</b>	Clutch Lever	1
1c	<b>MT.3329</b>	Clutch Lever Rivet	1
1d	<b>MT.2309</b>	Clamping Knob	1
1e	<b>MT.3058</b>	Clutch Catch Spring	1
1f	<b>MT.3330</b>	Clutch Catch Rivet	1
1g	<b>MT.152</b>	Clutch Control Spring	1
1h	<b>MT.3294</b>	Handle Grip	1
1i	<b>MT.3543</b>	Upper Cross Bar	1
1j	<b>MT.2634</b>	Spacing Collar Long	1
1k	<b>MT.3529</b>	Locking Bolt	1
1l	<b>UFS/106/16/SS.ZP</b>	Bolt	1
1m	<b>W6/S/SH.ZP</b>	Washer	1
1n	<b>MT.2931</b>	Locknut	1
2	<b>MT.3528</b>	Handle Assembly L.H.	1
	(Comprising)		
2a	<b>MT.3533</b>	Handle Weld Assembly L.H.	1
2b	<b>MT.3294</b>	Handle Grip	1
2c	<b>MT.2634</b>	Spacing Collar Long	1
2d	<b>UFS/106/16/SS.ZP</b>	Bolt	1
2e	<b>W6/S/SH.ZP</b>	Washer	1
2f	<b>MT.2931</b>	Locknut	1
3	<b>MT.3683</b>	Handle Mounting Assembly	1
	(Comprising)		
3a	<b>MT.3552</b>	Handle Mounting Bracket	1
3b	<b>MT.3554</b>	Spacing Collar Short	2
3c	<b>MT.3887</b>	Cable Guide	1
3d	<b>MT.4174</b>	Nameplate	1
3e	<b>WD.139</b>	Screws	2
3f	<b>UFB/106/38/SS.ZP</b>	Bolt	2
3g	<b>W6/S/SH/ZP</b>	Washer	1
3h	<b>MT.2931</b>	Locknut	2
3i	<b>MT3545</b>	Locking Plate	2
4	<b>MT.3061</b>	Clamp Handle	1
5	<b>MT.3530</b>	Cup Square Bolt	1
6	<b>MT.3616</b>	Spacer	1
7	<b>MT.3544</b>	Stay	2
8	<b>MT.3982</b>	Clutch Cable Assembly	1
9	<b>KK.683</b>	Cable Grip Rubber	1
10	<b>UFB/108/56/SB.ZP</b>	Pivot Bolt	1
11	<b>MT.3297</b>	Handle Spacer	1
12	<b>MT.3765</b>	Cable Guide	1
13	<b>W8/S/SH/ZP</b>	Washer	1
14	<b>MT.3332</b>	Locknut	1
15	<b>MT.4148</b>	Throttle Control	1
16	<b>2BAS/100/28/S.ZP</b>	Screw	2
17	<b>2BAN/100/S.ZP</b>	Hexagon Nut	2

15

## STRAIGHT HANDLEBAR ASSEMBLY

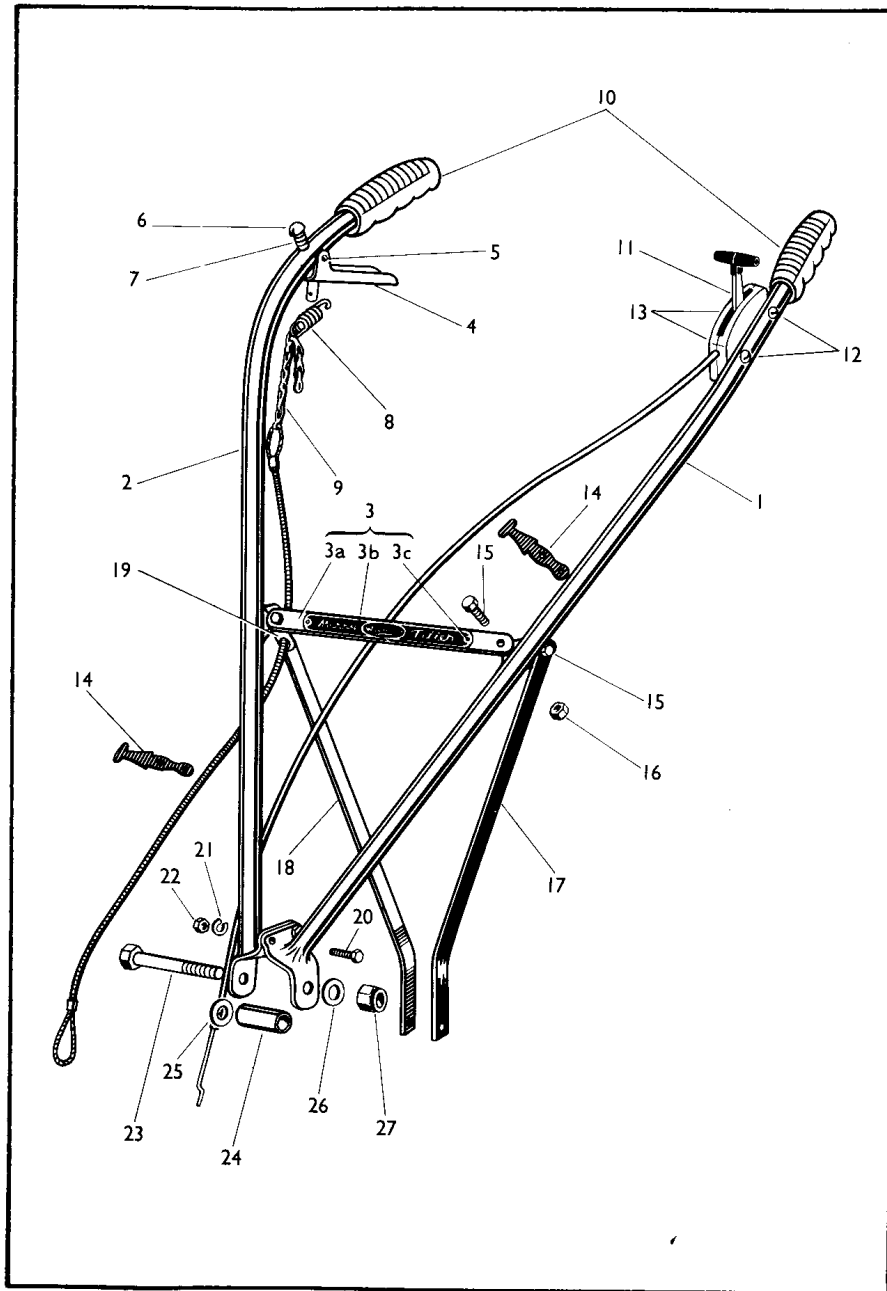

16

Copied from the original Merry Tiller Manual circa 1976

## FIXED HANDLE ASSEMBLY

ITEM No.	PART No.	PART NAME	Quantity per Machine
1	MT.4051	L.H. Handle	1
2	MT.4052	R.H. Handle	1
3	MT.1198	Cross Bar Assembly	1
	(Comprising)		
3a	MT.1199	Cross Bar	1
3b	MT.1106	Nameplate	1
3c	WD.139	Screws	2
4	MT.3311	Clutch Lever	1
5	MT.3329	Rivet	1
6	MT.3330	Clutch Catch Rivet	1
7	MT.3058	Clutch Catch Spring	1
8	MT.152	Clutch Control Spring	1
9	MT.3982	Clutch Cable	1
10	MT.3294	Handle Grip	2
11	MT.4148	Throttle Control	1
12	2BAS/600/28/S.ZP	Screws	2
13	2BAN/100/S.ZP	Nut (Not shown)	2
14	KK.683	Cable Clip	2
15	UFB/106/16/SS.ZP	Bolt	4
16	MT.2931	Locknut	4
17	MT.3331	Stay L.H.	1
18	MT.3320	Stay R.H.	1
19	MT.3887	Cable Guide	1
20	UFB/104/14/SS.ZP	Bolt	2
21	LW.4	Washer	2
22	UFN/104/S.ZP	Nut	2
23	UFB/108/56/SB.ZP	Pivot Bolt	1
24	MT.3297	Spacer	1
25	W8/S/SL/ZP	Washer	1
26	W8/S/SH/ZP	Washer	1
27	MT.3332	Locknut	1

17

Produced by allotment.org.uk in response to requests

As manufacturers Wolseley Webb Limited hope that you will be satisfied with the performance of your Merry Tiller. In order to make your gardening easier and give you more time for relaxation, we would draw your attention to the items below which can give you all year round use for your machine.  
This is not a complete list of Accessories.

Pick Rotors.  
Reverse Drive.  
Row Crop Equipment - Standard and Heavy Duty.  
Lawn Care and Turf Management Equipment.  
Grasscutting Equipment - Rotary  
Load Carrier.  
Bulldozer Blade  
Vee Plex Pulley (Required for power driven tools)  
Canvas Cover  
Truck  
Soil Shredder  
Seed and Fertilizer Distributor